

Gooseneck Wall Mount PWM20G Videolarm for Panasonic

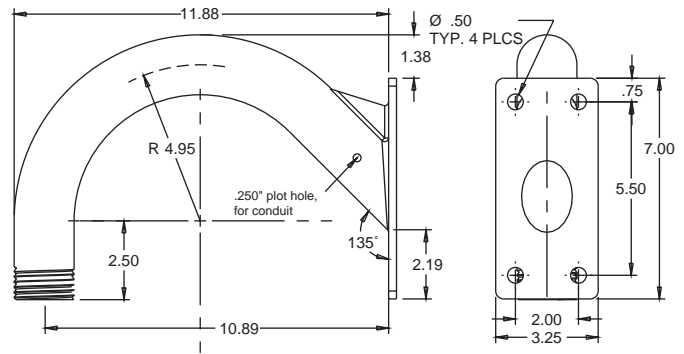

1
Outdoor Dome Brackets and Mounts



DESCRIPTION

With its distinctive gooseneck design, the PWM20G presents a sleek, aesthetically pleasing look. This wall mount will support most VIDEOLARM outdoor domes, as well as those of many other manufacturers.

FEATURES:

- Durable powder coat finish
- All aluminum construction
- 1 1/2" pipe thread on end for quick and easy dome mounting
- 75 lb load rating

Model	Unit Weight	Shipping Weight	Shipping Box Dim.
PWM20G	2.5 lbs	2.5 lb	15" x 12" x 12"

* Shipping weights depend on box dimensions.

Spec#	Rev. Date	Catalog Section	VidFax#
6024	0195	1	S24

Due to our continued efforts to advance technology, product specifications are subject to change without notice.

24-hour technical assistance
1-800-554-1124
2525 Park Central Blvd.
Decatur, GA 30035

Phone: (770) 987-7550
1-800-554-1124
U.S. & Canada only

Fax: (770) 987-9705
1-800-826-0366
VidFax: 1-800-547-5044

Email: info@videolarm.com
www.videolarm.com